

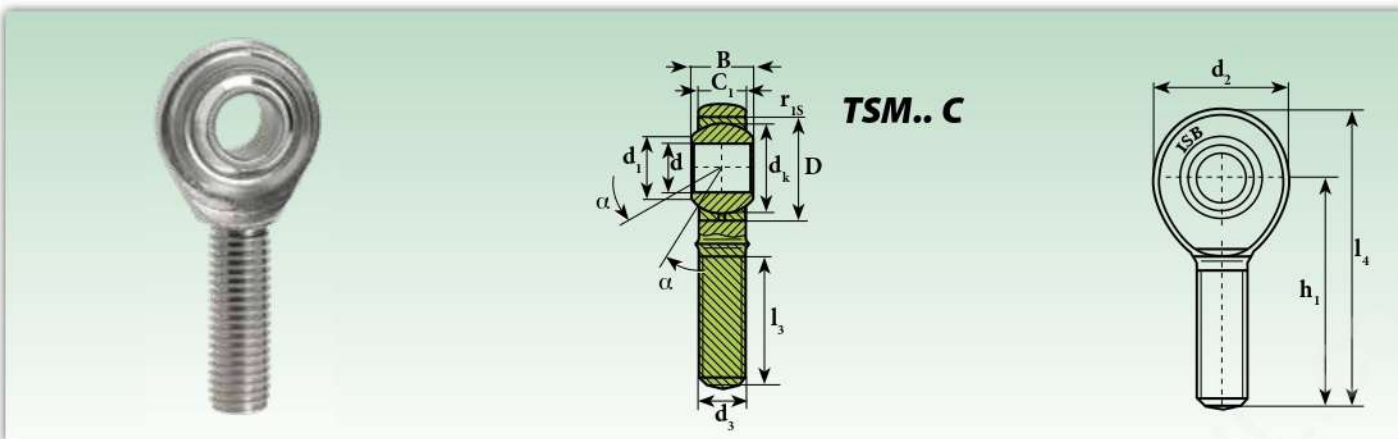

Teste a snodo (esenti da lubrificazione)

Rod ends (maintenance-free)



Sigla ¹⁾ Designation ¹⁾	Dimensioni mm Dimensions mm											Gradi Degrees	Distanza dagli spigoli (mm.) Distance from edges (mm.)	Coefficienti di Carico Ratings load		Peso Weight
	d H7	d ₁	d ₂	d ₃	d _k	B	C ₁	D	h ₁	l ₃	l ₄			r _{1smin}	Dinamico C Dinamyc C KN	
TSM 5 C	5	7,7	18	M 5x0,8	11,11	8	7,5	13	33	19	42	13	0,3	3,2	5,2	0,01
TSM 6 C	6	8,9	20	M 6x1	12,70	9	7,5	16	36	21	46	13	0,3	4,2	6,7	0,020
TSM 8 C	8	10,3	24	M 8x1,25	15,88	12	9,5	19	42	25	54	14	0,3	7	9,9	0,03
TSM 10 C	10	12,9	28	M 10x1,5	19,05	14	11,5	22	48	28	63	13	0,3	9,6	12,4	0,05
TSM 12 C	12	15,4	32	M 12x1,75	22,23	16	12,5	26	54	32	71	13	0,3	13	14,8	0,085
TSM 12.1 C	12	15,4	32	M 12x1,25	22,23	16	12,5	26	54	32	71	13	0,3	13	14,8	0,085
TSM 14 C	14	16,8	36	M 14x2	25,40	19	14,5	29	60	36	79	16	0,3	16,8	25,4	0,12
TSM 16 C	16	19,3	42	M 16x2	28,58	21	15,5	32	66	37	87	15	0,3	21,3	34,3	0,18
TSM 16.1 C	16	19,3	42	M 16x1,5	28,58	21	15,5	32	66	37	87	15	0,3	21,3	34,3	0,18
TSM 18 C	18	21,8	44	M 18x1,5	31,75	23	17,5	35	72	41	95	15	0,3	25,8	41,4	0,26
TSM 20 C	20	24,3	50	M 20x1,5	34,93	25	18,5	40	78	45	103	14	0,3	30,9	49,8	0,34
TSM 22 C	22	25,8	54	M 22x1,5	38,10	28	21	42	84	48	112	15	0,3	37,8	58,3	0,43
TSM 25 C	25	29,5	60	M 24x2	42,85	31	23	47	94	55	124	15	0,3	48,1	69,8	0,64
TSM 28 C	28	32,3	66	M 27x2	47,60	35	26	-	103	62	136	15	0,3	60	78,4	0,87
TSM 30 C	30	34,8	70	M 30x2	50,80	37	27	55	110	66	145	17	0,3	71,9	96,7	1,07
TSM 35 C	35	-	81	M 36x2	57,15	43	28	-	140	85	180,5	16	0,3	-	-	1,64
TSM 40 C	40	-	91	M 42x2	66,67	49	33	-	150	90	195,5	17	0,3	-	-	2,3
TSM 50 C	50	-	117	M 48x2	82,5	60	45	-	185	105	243,5	17	0,3	-	-	4,8

Su richiesta, disponibili in acciaio inox (anello interno AISI 440 C o 420C - anello esterno AISI 316)
Under request, stainless steel available (AISI 440 C or 420C inner ring - AISI 316 outer ring)

¹⁾ Per filettatura a sinistra aggiungere il suffisso "L" (esempio: TSML.C)
 The shank of ball joint housing may be left-hand thread, for left-hand thread suffix "L" is added (example: TSML.C)

Accoppiamento di strisciamento: acciaio/PTFE
 Sliding coupling: steel/PTFE
 TSM..C equivalente a equivalent to: GAKR..-PW INA e and SAKB..F SKF
 * Lunghezza minima Minimum lenght

